



USER GUIDE

LiFePO4 Battery System for Households



Shenzhen Kamada Electronic Co., Ltd

Web: www.kmdpower.com

E-mail: marketing@kmdpower.com

Address: Building 4, Mashaxuda High-tech Industry Park, Pingdi Street,
Longgang District 518117, Shenzhen, Guangdong, P.R.China.

Fax: +86-755-23229135 Tel: +86-755-2833 2245

Contents

1.ABOUT THIS MANUAL	1
1.1 Purpose	1
1.2 Scope	1
1.3 Safety Instructions	1
2.INTRODUCTION	2
2.1 Features	2
2.2 Product Over View	2
2.3 Specifications	4
2.4 Mounting the Unit	5
3.INSTALLATION	6
3.1 Diagram of accessories	6
3.2 Description of accessories	6
3.3 Installation steps	7
4.OPERATION	8
4.1 Function introduction	8
4.2 Communication introduction	9
4.3 Interface definition	10
4.4 Switch ON / OFF	10
4.5 ON / OFF or SOC Led (Mode or SOC)	12
4.6 Connection for Parallel Mode	14
5.EMERGENCY SITUATIONS	15
5.1 Fire	15
5.2 Leaking Batteries	15
5.3 Wet Batteries	15
5.4 Warranty	15

1 ABOUT THIS MANUAL

1.1 Purpose

This manual describes the introduction, installation, operation and emergency situations of the battery bank. Please read this manual carefully before installations and operations. Keep this manual for future reference.

1.2 Scope

This manual provides safety and installation guidelines as well as information on tools and wiring.

1.3 Safety Instructions



WARNING: This chapter contains important safety and operating instructions. Read and keep this manual for future reference.

1. Before using the unit, read all instructions and cautionary markings on the unit, the batteries and all appropriate sections of this manual.
2. CAUTION --- To reduce risk of injury, damage, even burst, please use it following using manual. In case of causing personal
3. Do not disassemble the battery. Take it to a qualified service center when service or repair is required. Incorrect re-assembly may result in a risk of fire.
4. To reduce risk of electric shock, disconnect all wirings before attempting any maintenance or cleaning. Turning off the unit will not reduce this risk.
5. CAUTION – Only qualified personnel can install this device with inverter.
6. For optimum operation of this battery, please follow required spec to select appropriate cable size.
7. Be very cautious when working with metal tools on or around batteries. A potential risk exists to drop a tool to spark or short circuit batteries or other electrical parts and could cause an explosion or fire.
8. Please strictly follow installation procedure.

1.4 Can be connected in parallel

1. The batteries can be connected in parallel. Series connection is not allowed. Use in upright position only.
2. The batteries are not allowed to connected with PWM controller for charging.

Special Attention: Due to the built-in protection board of the lithium battery pack is with over-discharge protection function, it is strongly recommended to stop using the load when the battery pack is over-discharged. The battery pack cannot be repeatedly activated for discharge. Therefore, when the battery pack is low power, please charge the battery as soon as possible when main power or solar energy is available.

2. INTRODUCTION

The battery system main using Solar power system for Family house. It also have a with to controller the battery easily and protect our Household application timely.

2.1 Features

- Iron phosphate-lithium power battery
- Long warranty period: 5 years
- Higher energy density, smaller volume for household.
- Support connected in parallel mode for expansion
- Photovoltaic system: This battery pack is designed for household photovoltaic systems.
- Battery management system (BMS): The battery packs built-in BMS monitors its operation and prevents the battery from operating outside design limitations.
- Expandability: This battery pack can be easily expanded by adding expansion battery packs in parallel connection.

2.2 Product Over View

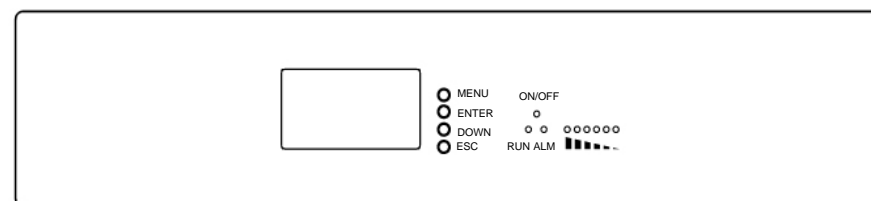
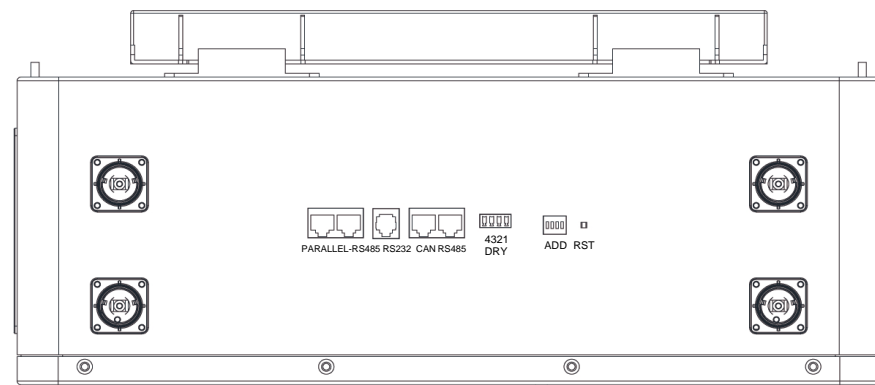
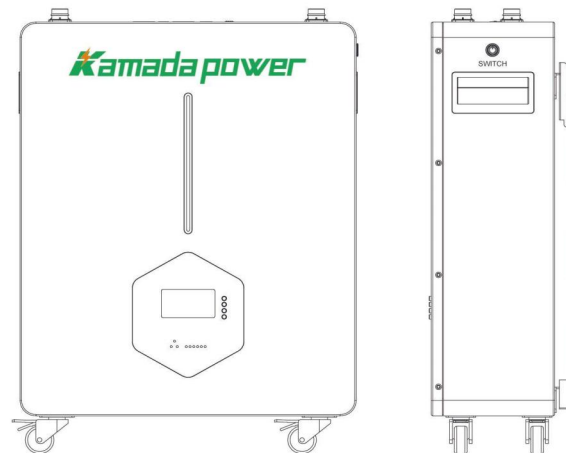
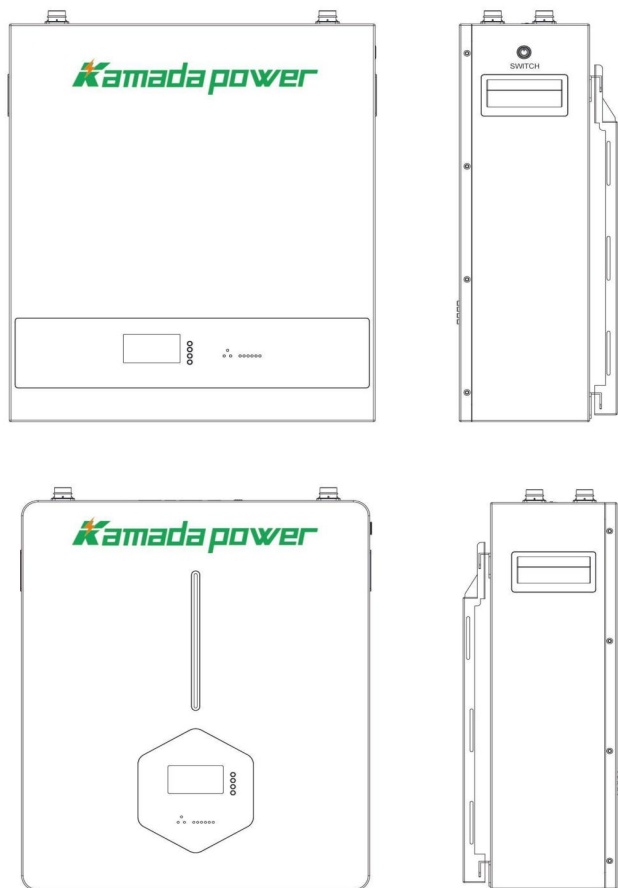

2.3 Specifications

Battery Specifications	KMD-PL4850	KMD-PL48100	KMD-PL48150	KMD-PL48200
ELECTRICAL				
Nominal Voltage	48V/51.2V			
Energy Capacity	50Ah(2.5KWH)	100Ah(5KWH)	150Ah(7.5KWH)	200Ah(10KWH)
Battery Type	LFP(LiFePO4)			
Depth Of Discharge (DoD)	95%			
OPERATION				
Max. Charging Current	30A @25°C	90A @25°C	90A @25°C	90A @25°C
Max. Discharging Current	50A @25°C	120A @25°C	120A @25°C	120A @25°C
Operating Temperature Range	0°C ~ +50°C(Charging)/-20°C ~ +60°C(Discharging)			
Storage Temperature Range	-30°C ~ +60°C			
Humidity	5% ~ 95%			
BMS				
Modules Connection	Max 15 Batteries In Parallel			
Power Consumption	<2 W			
Communication	RS485/RS232/CAN(Optional)			
PHYSICAL				
Dimensions (Lx W x H)(mm)	464x330x160	547x461x163	510x445x208	547x471x248
Dimensions(With Wheels)	469x330x160	552x461x163	515x445x208	552x471x248
Weight	30KGS	45KGS	65KGS	89KGS
Weight(With Wheels)	31KGS	46KGS	66KGS	90KGS
Option	Wheels			
Ingress Protection Rating	IP20			
Cycle life	Around 6000 Times			
Warranty	5 Years Product Warranty, 10 Years Design Life Warranty			
CERTIFICATE				
Certificate	CE/UN38.3/MSDS			

2.4 Mounting the Unit

Consider the following points before selecting where to install:

- Do not mount the battery on flammable construction materials.
- The ambient temperature should be between 0°C and 45°C to ensure optimal operation.
- The recommended installation position is to be adhered to the wall vertically.
- Be sure to keep other objects and surfaces as shown in the right diagram to guarantee sufficient heat dissipation and to have enough space for removing wires.
- Refer to the attached figure for installation hole positions and screw hole sizes of wall mounting supports.

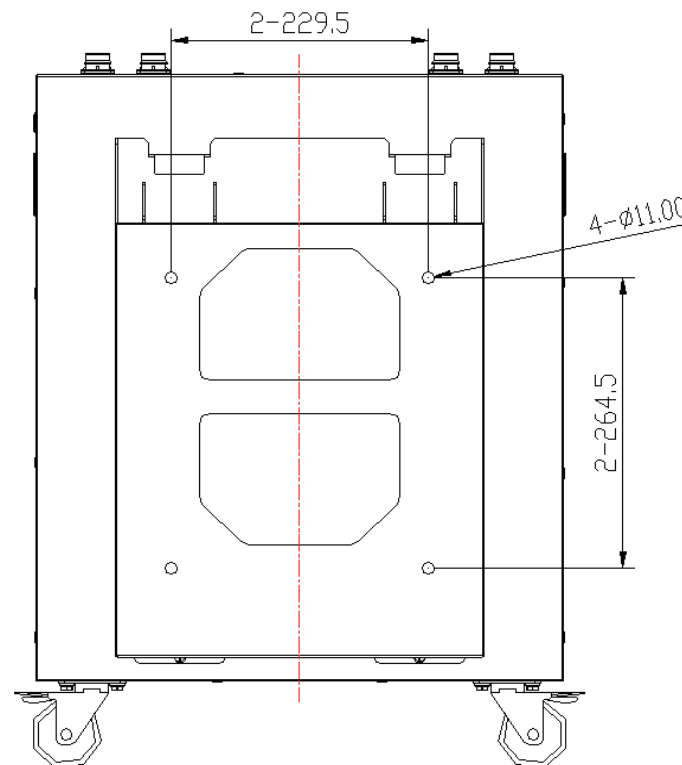

3. INSTALLATION

3.1 Diagram of accessories

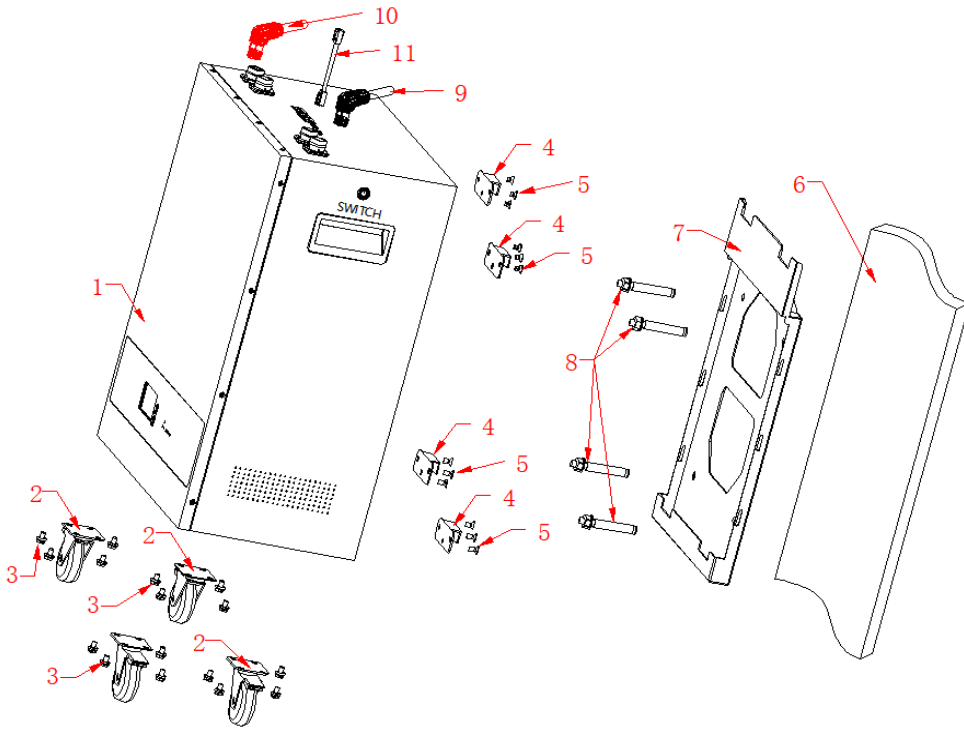

3.2 Description of accessories

No.	Part Name	Specification
1	Battery	KMD-PL4850/KMD-PL48100/KMD-PL48150/KMD-PL48200
2	Caster wheel	Different products with corresponding castors
3	Screws	Screw-Stainless steel natural color-Passivated-M6x10-Machine tooth-Crossed flat head-No combination
4	Mounting ears on the back of the battery	Mounting ears on the back of the battery SPCC surface powder-coated black matte fine sand pattern-80x35x15mm-wall thickness 2mm-3 through-holes with a diameter of 7mm are integrally formed
5	Screws	Match the corresponding screws according to the casters

6	Load-bearing walls	1. If one battery is hung on the wall: the load-bearing wall of models KMD-PL4850 and KMD-PL48100 is 100KG 2. If one battery is hung on the wall: the load-bearing wall of models KMD-PL48150, KMD-PL48200 and KMD-PL48300 is 200KG 3. If multiple batteries are hung on a load-bearing wall, the load-bearing capacity will increase accordingly
7	Wall Mount Bracket	Corresponding wall brackets are equipped according to different battery specifications
8	Expansion screws	Outer hexagon expansion screw GB/T5285-1985-M10X80-8.8
9	Output negative power cable	According to different battery specifications and customer needs, match the corresponding output negative power line
10	Output positive power cable	According to different battery specifications and customer needs, match the corresponding output positive power line
11	Communication line between inverter and battery	According to different inverters and customer needs, the corresponding communication network cable is equipped. If the customer does not inform the inverter of the detailed information, we will not provide this communication network cable.

3.3 Installation steps

Assembly and commissioning step number	name	Assembly Instructions
step 1	Assemble casters	a.Lock the casters to the bottom of the battery with screws
step 2	Assembled battery back lugs	b.Lock the wall hook to the back of the battery with screws
step 3	Assembling wall brackets	c.Screw expansion screws to the load-bearing wall
step 4	Wall Mount Battery	d.Hang the battery on the wall mount
step 5	Pair plugging positive and negative power cables	e.Insert the positive and negative power cord pairs between the battery and the inverter
step 6	Docking inverter and battery communication cable	f.According to the communication protocol port of the inverter, one end of the communication line between the inverter and the battery is plugged into the CAN or RS485 port of the battery, and the other end is plugged into the inverter.
step 7	Dial the ADD address switch	g.If it is a battery, dial 1, and the rules of other dialing addresses are detailed in the attached page.
step 8	turn on the switch	h.Press the power switch on the side to let the ON/OFF RUN 6 battery indicator lights display in green

4. OPERATION

4.1 Function introduction

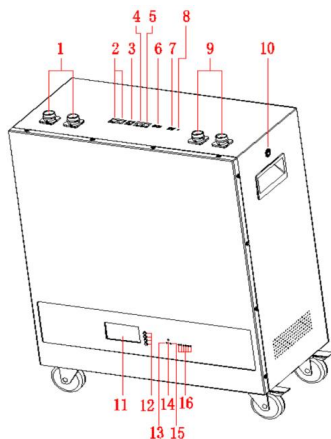

No.	Name	Function Description
1	Power Positive Terminal	Power positive output, two terminals with the same positive terminal is a parallel output
2	RS485 Communication Interface	1. Testing battery performance 2. When multiple batteries are used in parallel, it acts as a communication connection port between batterie
3	RS232 Communication Interface	Testing and modifying battery parameters
4	CAN Communication Interface	Connection to CAN port of inverter
5	RS485 Communication Interface	Connection to RS485 port of inverter
6	DRY Communication Interface	DRY output terminal Dry contact 1-PIN1 to PIN2: Normally open, closed when fault protection; Dry contact 2-PIN3 to PIN4: Normally open, alarm closed when low battery
7	ADD Address Switch	When connecting batteries in parallel by dialing the code Address identification of different batteries (see attached page for dialing rules)

8	RST Button (Electronic)	1. You can turn on and off the battery, the default is automatically turned on when the power switch is turned on, long press for 3 seconds, when the power indicator is flashing, release to automatically turn off the battery output 2. After battery troubleshooting, if the ALM indicator is still on, press the RST button for 3-5 seconds, when the power indicator is flashing, release the ALM indicator to turn off
9	Power Negative Terminal	Power negative output, two terminals with negative terminal is parallel output
10	Power Switch(Mechanical)	Turn on and off the battery
11	Display	Display all basic parameters of the battery
12	4 Display Buttons	MENU ENTER DOWN ESC
13	RUN Indicator	The indicator light is on to indicate that the battery is functioning normally
14	ON/OFF Indicator	The indicator light is on to indicate that the battery is on
15	ALM Indicator	The indicator light is on to indicate a battery alarm or fault
16	6 Power Indicators	Different power levels show different number of indicators

4.2 Communication introduction

RS232

BMS can communicate with the upper computer through RS232 interface, so that the upper computer can monitor all kinds of battery information, including battery voltage, current, temperature, status and battery production information, etc. The default baud rate is 9600bps.

CAN

CAN communication, the default communication rate is 500K.

RS485

With dual RS485 interfaces, you can view PACK information, and the default baud rate is 9600bps. If you need to communicate with the monitoring device through RS485, the monitoring device is the host, polling data according to the address, The address setting range is 1~15.

4.3 Interface definition

Communication Interface Diagram

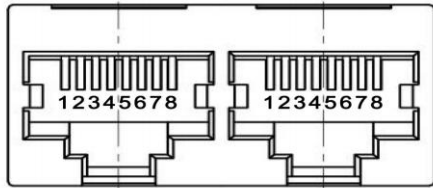

CAN and RS485 interface



Dry contact

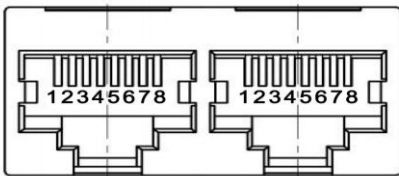

Parallel communication port

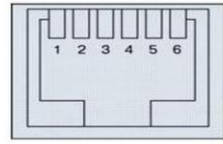

RS232 communication port

Electrical Interface Definition

RS232--Adopt 6P6C vertical RJ11 socket	
RJ11 pin	Definition description
2	NC
3	TX (vener)
4	RX (vener)
5	GND

CAN-- adopts 8P8C vertical RJ45 socket		RS485-- 8P8C vertical RJ45 socket	
RJ45 pin	specifies	RJ45 pin	specifies
1, 2, 3, 6, 8	NC	1, 8	RS485-B1
5	CANL	2, 7	RS485-A1
4	CANH	3, 6	GND
7	GND	4, 5	NC

CAN and RS485 interface

RS485-- 8P8C vertical RJ45 socket		RS485-- 8P8C vertical RJ45 socket	
RJ45 pin	specifies	RJ45 pin	specifies
1, 8	RS485-B	1, 8	RS485-B
2, 7	RS485-A	2, 7	RS485-A
3, 6	GND	3, 6	GND
4, 5	NC	4, 5	NC

Parallel communication port

Once the batteries are connected well, simply press On/Off button to enable the output of the battery pack.

4.4 Switch ON / OFF

Dial Switch

When PACK is used in parallel, different PACK can be distinguished by setting the address of ADD switch on BATTERY, and it is necessary to avoid setting the address to be the same. For the definition of BMS ADD switch, refer to the following table.



Address	Dial code switch position			
	#1	#2	#3	#4
0	OFF	OFF	OFF	OFF
1	ON	OFF	OFF	OFF
2	OFF	ON	OFF	OFF
3	ON	ON	OFF	OFF
4	OFF	OFF	ON	OFF
5	ON	OFF	ON	OFF
6	OFF	ON	ON	OFF
7	ON	ON	ON	OFF
8	OFF	OFF	OFF	ON
9	ON	OFF	OFF	ON
10	OFF	ON	OFF	ON
11	ON	ON	OFF	ON
12	OFF	OFF	ON	ON
13	ON	OFF	ON	ON
14	OFF	ON	ON	ON
15	ON	ON	ON	ON

4.5 ON / OFF or SOC Led (Mode or SOC)

LED instructions

Table 1 LED Working status indication

State	Normal / Alarm / Protection	ON/OFF	RUN	ALM	SOC Indication LEDs						Instructions
		●	●	●	●	●	●	●	●		
Power Off	Sleep	OFF	OFF	OFF	OFF	OFF	OFF	OFF	OFF	OFF	All off
Standby	Normal	ON	flash1	OFF	Indication by SOC						Standby
	Alarm	ON	flash1	Flash3							Cell low voltage
Charge	Normal	ON	ON	OFF	Indication by SOC (The top SOC Led Flash 2)						Maximum power LED flash(flash 2),ALM does not flash for over-charge warning
	Alarm	ON	ON	Flash3							
	Over Charge Protection	ON	ON	OFF	ON	ON	ON	ON	ON	ON	If no mains supply, LED as standby
	Temperature. Over-current. Fault Protection	ON	OFF	ON	OFF	OFF	OFF	OFF	OFF	OFF	Close charge
Discharge	Normal	ON	Flash3	OFF	Indication by SOC						Close discharge
	Alarm	ON	Flash3	Flash3							
	Temperature. Over-current. Short Circuit Fault Protection	ON	OFF	ON	OFF	OFF	OFF	OFF	OFF	OFF	Close discharge
Fault		OFF	OFF	ON	OFF	OFF	OFF	OFF	OFF	OFF	Close charge Close discharge

Table 2 Capacity indication

State	Charge						Discharge					
	L6	L5	L4	L3	L2	L1	L6	L5	L4	L3	L2	L1
Capacity indicator light	●	●	●	●	●	●	●	●	●	●	●	●
electricity (%)	0~16.6%	OFF	OFF	OFF	OFF	flash2	OFF	OFF	OFF	OFF	OFF	ON
	16.6~33.2%	OFF	OFF	OFF	OFF	flash2	ON	OFF	OFF	OFF	ON	ON
	33.2~49.8%	OFF	OFF	OFF	flash2	ON	ON	OFF	OFF	OFF	ON	ON
	49.8~66.4%	OFF	OFF	flash2	ON	ON	ON	OFF	OFF	ON	ON	ON
	66.4~83.0%	OFF	flash2	ON	ON	ON	ON	OFF	ON	ON	ON	ON
	83.0~100%	flash2	ON	ON	ON	ON	ON	ON	ON	ON	ON	ON
Running light ●	ON						flash(flash 3)					

Table 3 LED Flash description

Flashing way	ON	OFF
FLASH 1	0.25S	3.75S
FLASH 2	0.5S	0.5S
FLASH 3	0.5S	1.5S

Note: The LED indicator alarm can be enabled or disabled by the host computer. It is enabled by factory default.

4.6 Connection for Parallel Mode

1. The ADD address of this battery wired with the inverter is 1, other batteries dial the corresponding address according to the dial code address rule
2. Continuous current 100A. 6AWG or 4AWG wire is recommended for the power cord

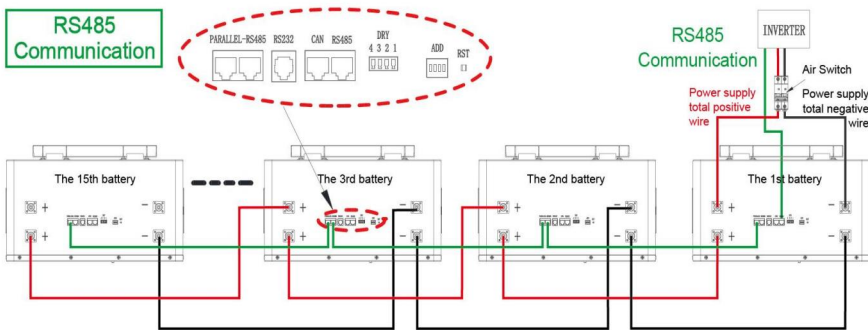
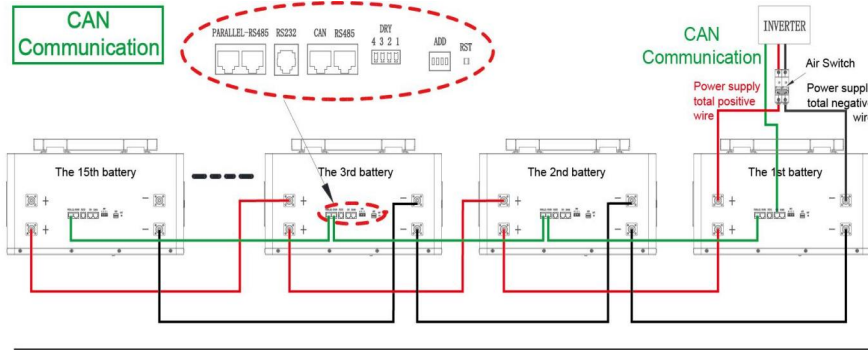

5. EMERGENCY SITUATIONS

KMD cannot guarantee battery absolute safety.

5.1 Fire

In case of fires, make sure that the following equipment is available near the system.

- SCBA (self-contained breathing apparatus) and protective gear in compliance with the Directive on Personal Protective Equipment 89/686/EEC.

- NOVEC 1230, FM-200, or dioxide extinguisher

Batteries may explode when heated above 130°C. KEEP FAR AWAY from the battery if it catches fire.

5.2 Leaking Batteries

If the battery pack leaks electrolyte, avoid contact with the leaking liquid or gas. If one is exposed the leaked substance, immediately perform the actions described below.

- Inhalation: Evacuate the contaminated area, and seek medical attention.
- Contact with eyes: Rinse eyes with running water for 5 minutes, and seek medical attention.
- Contact with skin: Wash the affected area thoroughly with soap and water, and seek medical attention.
- Ingestion: Induce vomiting, and seek medical attention.

5.3 Wet Batteries

If the battery pack is wet or submerged in water, do not let people access it, and contact your supplier for help.

Damaged Batteries

Damaged batteries are not fit for use and are dangerous and must be handled with the utmost care. It may leak electrolyte or produce flammable gas. If the battery pack seems to be damaged, pack it in its original container, and then return it to your supplier.

5.4 Warranty

Products that are operated strictly in accordance with the user manual are covered by the warranty. Any violation of this manual may void the warranty.

Limitation of Liability

Any product damage or property loss caused by the following conditions, KMD does not assume any director indirect liability.

- Product modified, design changed or parts replaced.
- Changed, or attempted repairs and erasing of series number or seals;
- System design and installation are not in compliance with standards and regulations;
- The product has been improperly stored in end user's premises;
- Transport damage (including painting scratch caused by movement inside packaging during shipping). A claim should be made directly to shipping or insurance company.